

HS1V H03 SERIES

Current Sensor

Model Number

HS1V 50 H03
HS1V 100 H03
HS1V 200 H03
HS1V 300 H03
HS1V 400 H03
HS1V 500 H03
HS1V 600 H03

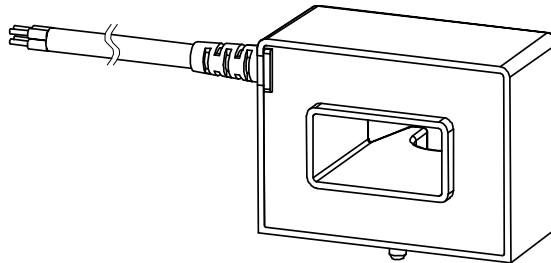

For the electronic measurement of current: DC, AC, pulsed..., with galvanic separation between the primary and the secondary circuits.

Features

- ◇ Open loop current sensor using the Hall effect
- ◇ Output voltage is proportional to the supply voltage
- ◇ Galvanic separation between primary and secondary
- ◇ Insulating plastic case recognized according to UL 94-V0
- ◇ No insertion losses
- ◇ Small size
- ◇ Standards:
 - IEC 60664-1:2020
 - IEC 61800-5-1:2022
 - IEC 62109-1:2010

Applications

- ◇ AC variable speed
- ◇ Uninterruptible Power Supply (UPS)
- ◇ Static converters for DC motor drives
- ◇ Switch Mode Power Supplies (SMPS)
- ◇ Power supplies for welding applications
- ◇ Battery management
- ◇ Wind energy inverter

Safety

This sensor must be used according to IEC61800-5-1.

This sensor must be used in electric/electronic equipment with respect to applicable standards and safety requirements in accordance with the following manufacture's operating instructions.

Caution, risk of electrical shock!



When operating the sensor, certain parts of the module can carry hazardous voltage (e.g., Primary busbar, power supply). Ignore this warning can lead to injury and/or cause serious damage.

This sensor is a built-in device, whose conducting parts must be inaccessible after installation. A protective housing or additional shield could be used.

Main supply must be able to be disconnected.

HS1V H03 SERIES

Absolute maximum ratings(not operating)

Parameter	Symbol	Unit	Value
Supply voltage	V_C	V	±18V
Primary conductor temperature	T_B	°C	100

✘ Stresses above these ratings may cause permanent damage.

✘ Exposure to absolute maximum ratings for extended periods may degrade reliability.

Environmental and mechanical characteristics

Parameter	Symbol	Unit	Min	Typ	Max	Comment
Ambient operating temperature	T_A	°C	-40		105	
Ambient storage temperature	T_S	°C	-40		105	
Mass	m	g		57		

Insulation coordination

Parameter	Symbol	Unit	Value	Comment
Rms voltage for AC insulation test @ 50Hz, 1min	V_d	kV	3.6	According to IEC 60664-1
Impulse withstand voltage 1.2/50µs	V_w	kV	6.6	According to IEC 60664-1
Clearance (pri.- sec.)	d_{cl}	mm	6.3	
Creepage distance (pri.- sec.)	d_{cp}	mm	7.3	
Plastic case	-	-	UL94-V0	
Comparative tracking index	CTI	PLC	3	
Application example	-	-	300V	Reinforced insulation, according to IEC 61800-5-1, IEC 62109-1CAT III, PD2
Application example	-	-	600V	Basic insulation, according to IEC 61800-5-1, IEC 62109-1CAT III, PD2

HS1V H03 SERIES

Electrical data

※ With $T_A = 25^\circ\text{C}$, $V_C = \pm 15\text{V}$, $R_L = 10\text{k}\Omega$, unless otherwise noted.

Parameter	Symbol	Unit	Min	Typ	Max	Comment
Primary nominal rms current	I_{PN}	A	-50		50	HS1V 50 H03
			-100		100	HS1V 100 H03
			-200		200	HS1V 200 H03
			-300		300	HS1V 300 H03
			-400		400	HS1V 400 H03
			-500		500	HS1V 500 H03
			-600		600	HS1V 600 H03
			Primary current, measuring range*1	I_{PM}	A	-150
-300		300				HS1V 100 H03
-600		600				HS1V 200 H03
-900		900				HS1V 300...600 H03
Supply voltage *1	V_C	V	± 12		± 15	@ 5%
Current consumption	I_C	mA		16 0.6		@+15V @-15V
Load resistance	R_L	k Ω	10			
Output voltage (Analog) @ I_{PN}	V_{OUT}	V		± 4.000		
Electrical offset voltage	V_{OE}	mV	-20		20	
Temperature coefficient of V_{OE} *2	TCV_{OE}	mV/K	-0.5		0.5	@ -40 $^\circ\text{C}$ ~105 $^\circ\text{C}$
Theoretical sensitivity	G_{th}	mV/A		80.00		HS1V 50 H03
				40.00		HS1V 100 H03
				20.00		HS1V 200 H03
				13.33		HS1V 300 H03
				10.00		HS1V 400 H03
				8.00		HS1V 500 H03
				6.67		HS1V 600 H03
Sensitivity error	ε_G	%	-0.5		0.5	exclusive of V_{OE}
Temperature of G	TCG	%/K	-0.1	± 0.05	0.1	@ -40 $^\circ\text{C}$ ~105 $^\circ\text{C}$
Linearity error 0... I_{PN}	ε_L	% of I_{PN}	-0.5		0.5	exclusive of V_{OE}
Hysteresis offset voltage @ $I_P=0$ after $1 \times I_{PN}$	V_{OM}	mV	-20		20	
Accuracy @ I_{PN}	X	% of I_{PN}	-1		1	exclusive of V_{OE}
Response time @ 90% of I_{PN}	t_r	μs		3	5	
Frequency bandwidth (-3dB)	BW	kHz	50			

*1: If $I_{PN} \leq 300\text{A}$ and powder supply voltage $V_C = \pm 12\text{V}$ current sensor, measurement range reduced to 2.5 times I_{PN} .

HS1V H03 SERIES

Dimensions (in mm. 1 mm = 0.0394 inch)

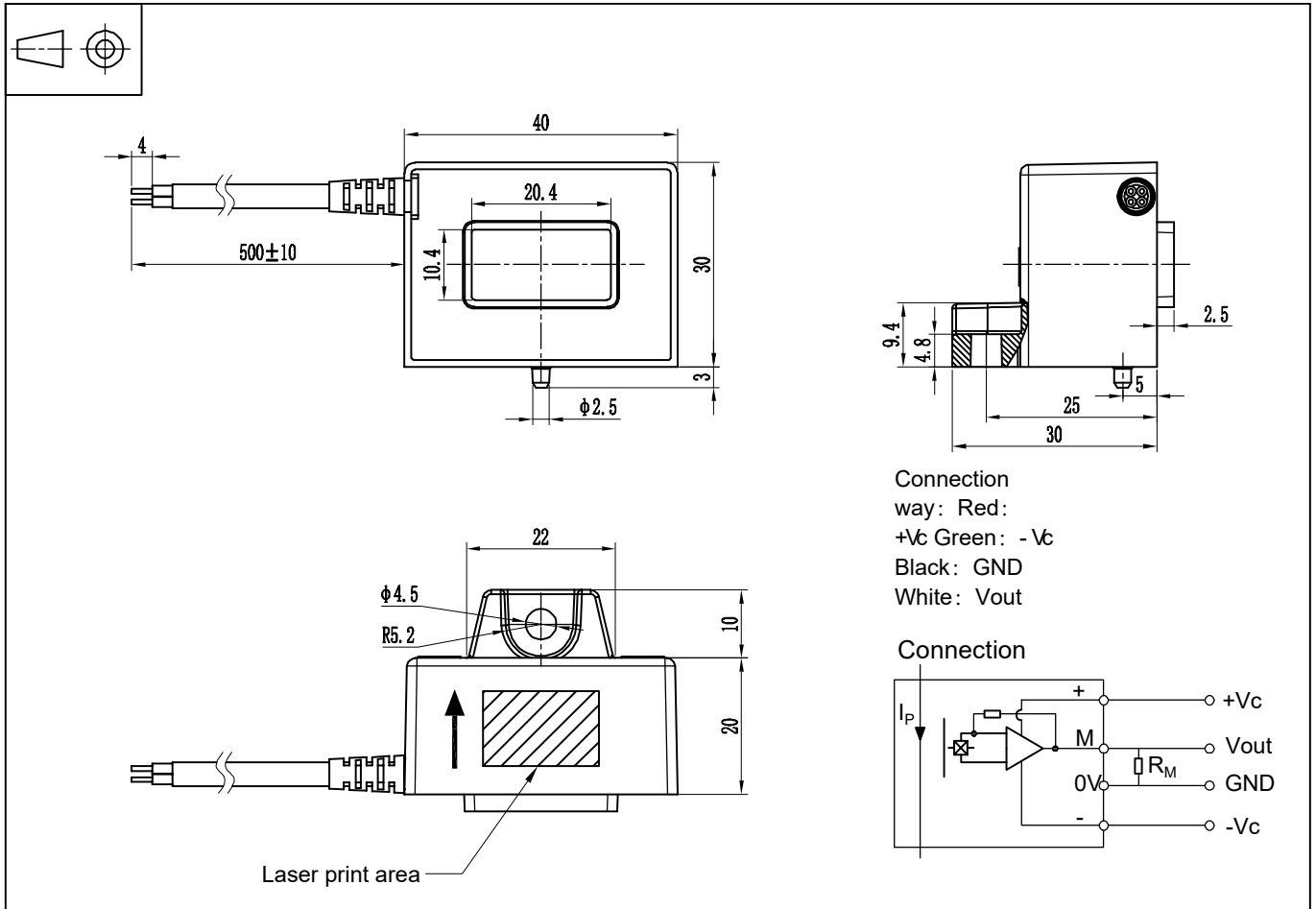

Mechanical characteristics

◇ General tolerance	±0.5 mm
◇ Connection of secondary	RVV4*0.2mm ²
◇ Output line length	500±10mm
◇ Primary hole	20.4mm×10.4mm
◇ Sensor	1pc Φ4.5 mm through hole 1pc M4 Metal screws

Recommended fastening torque 0.9 N•m (±10%)

Remarks

- ◇ V_{OUT} and I_P are in the same direction, when I_P flows in the direction of arrow.
- ◇ Temperature of the primary conductor should not exceed 105°C.
- ◇ Dynamic performances (di/dt and response time) are best with a single bar completely filling the primary hole.